

# ***PLT240***

## *LED Light Tower Parts Manual*

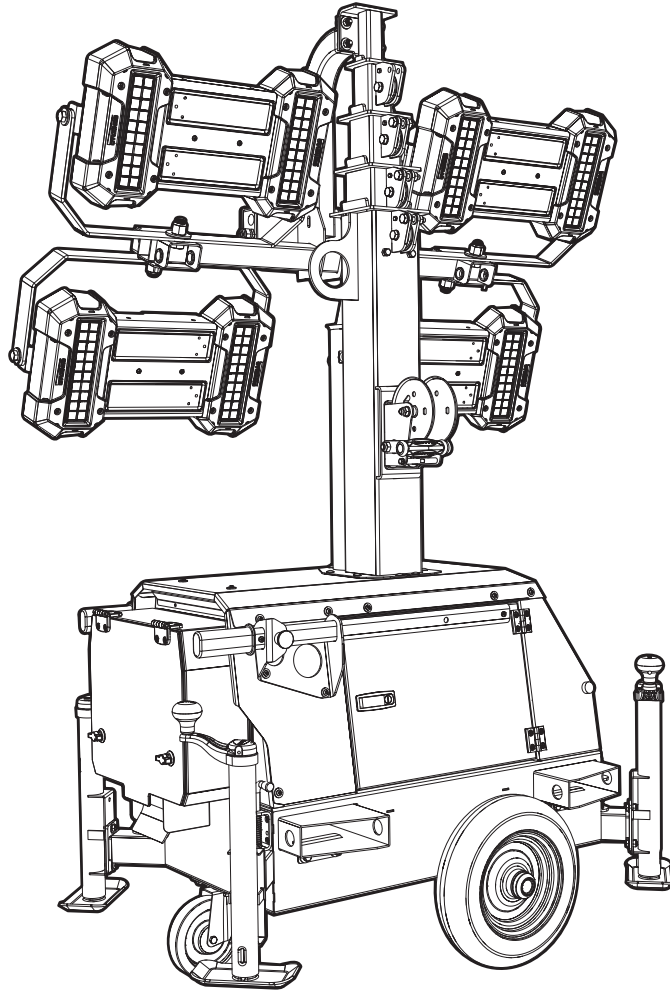

02243

MODEL NUMBER: \_\_\_\_\_

SERIAL NUMBER: \_\_\_\_\_

DATE PURCHASED: \_\_\_\_\_

***SAVE THIS MANUAL FOR FUTURE REFERENCE***

 **WARNING**

Breathing diesel engine exhaust exposes you to chemicals known to the State of California to cause cancer and birth defects or other reproductive harm.

- Always start and operate the engine in a well-ventilated area.
- If in an enclosed area, vent the exhaust to the outside.
- Do not modify or tamper with the exhaust system.
- Do not idle the engine except as necessary.

For more information go to

[www.P65Warnings.ca.gov/diesel](http://www.P65Warnings.ca.gov/diesel). (000394)

# Introduction

This parts manual was prepared based on the information available at the time of publication and is subject to change without notice. Generac Mobile Products reserves the right to change parts at any time. To check whether a revised parts manual is available, contact Generac Mobile Products.

DO NOT MODIFY or use this equipment for any application other than which it was designed for. To keep your equipment fully operational, it is suggested you maintain a stock of commonly used maintenance or service parts. A recommended spare parts list can be found in the back of this manual. To order service parts, please go to [www.generacmobileproducts.com](http://www.generacmobileproducts.com) or call Generac Mobile Products.



## **WARNING**

Consult Manual. Read and understand manual completely before using product. Failure to completely understand manual and product could result in death or serious injury. (000100a)

---

## **WARNING**

Environmental Hazard. Always recycle batteries at an official recycling center in accordance with all local laws and regulations. Failure to do so could result in environmental damage, death or serious injury. (000228)

---

## **GENERAC MOBILE PRODUCTS LLC**

**215 Power Drive • Berlin, WI 54923 U.S.A.**

**Phone: 920-361-4442**

**FAX: 920-361-4416**

**Toll Free: 1-800-926-9768**

**[www.generacmobileproducts.com](http://www.generacmobileproducts.com)**

**For technical or parts QUESTIONS, contact Generac Mobile Products Technical Service at 1-800-926-9768.**

Engine Make: \_\_\_\_\_

Engine Serial Number: \_\_\_\_\_

Engine Model Number: \_\_\_\_\_

This Page Intentionally Left Blank

# Table of Contents

Introduction .....	iii
Parts Manual Instructions .....	1
Unit Decals .....	2
Unit Decals .....	4
Lights, doors and Control Box to Unit .....	6
Enclosure Assembly .....	8
Light Mast Assembly .....	10
Light Assembly .....	12
Mast Junction Box Assembly - Hard Wired Lights .....	14
Mast Assembly .....	16
Mast Base Assembly .....	18
Control Panel Cover .....	20
Control Panel Assembly (1 of 3) .....	22
Control Panel Assembly (2 of 3) .....	24
Control Panel Assembly (3 of 3) .....	26
Trailer Assembly .....	28
Recommended Spare Parts .....	30

This Page Intentionally Left Blank

# Parts Manual Instructions

Product illustrations are only representations. Products supplied may vary from the illustrations in this parts manual. Parts not shown in the illustration are indicated by a double dash (--) in the item column.

Please be prepared to provide the following information when ordering replacement parts: model number, serial number (on unit serial tag), part number, purchase order number (if applicable), shipping address, shipping method.

Refer to the illustration below to locate the unit ID tag on the unit. Important information, such as the unit serial number, model number, and tire loading information are found on these tags. Record the information from these tags so it is available if the tags are lost or damaged. When ordering parts or requesting assistance, you may be asked to provide this information.

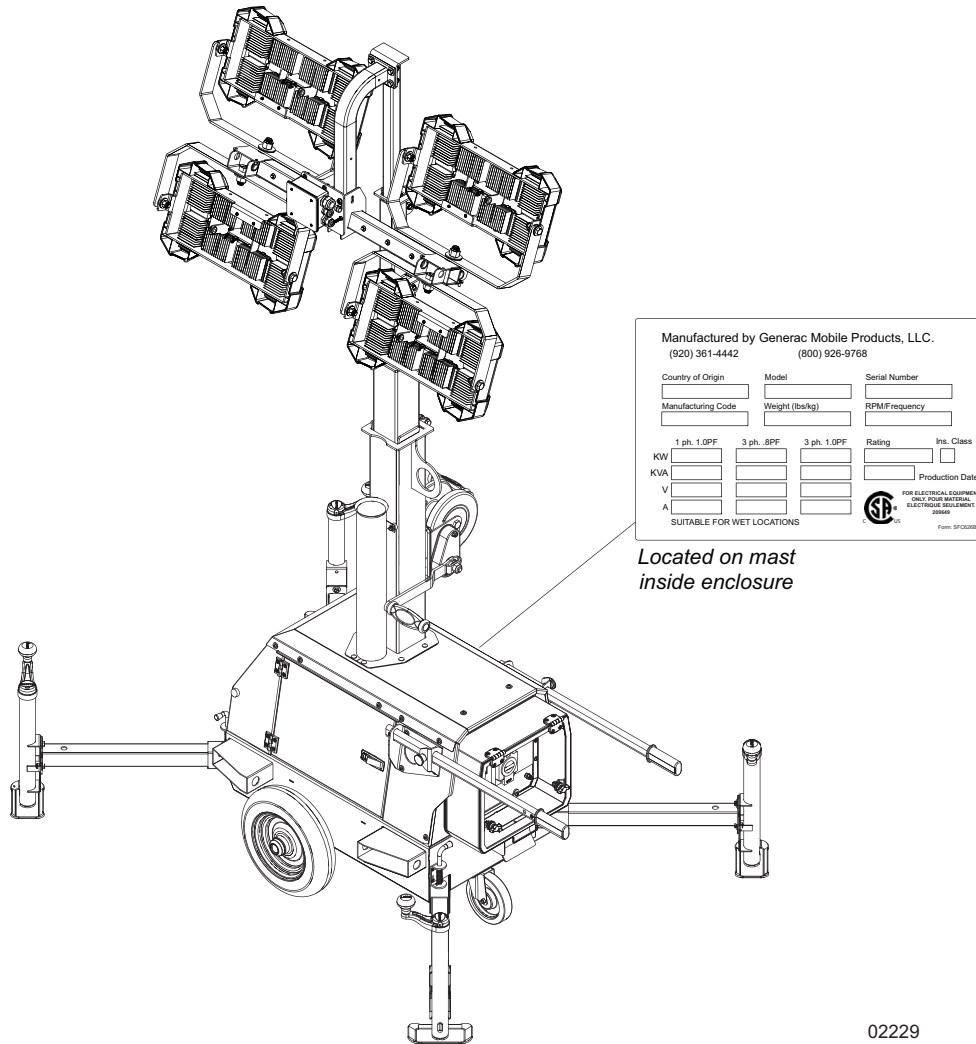

02229

# UNIT DECALS

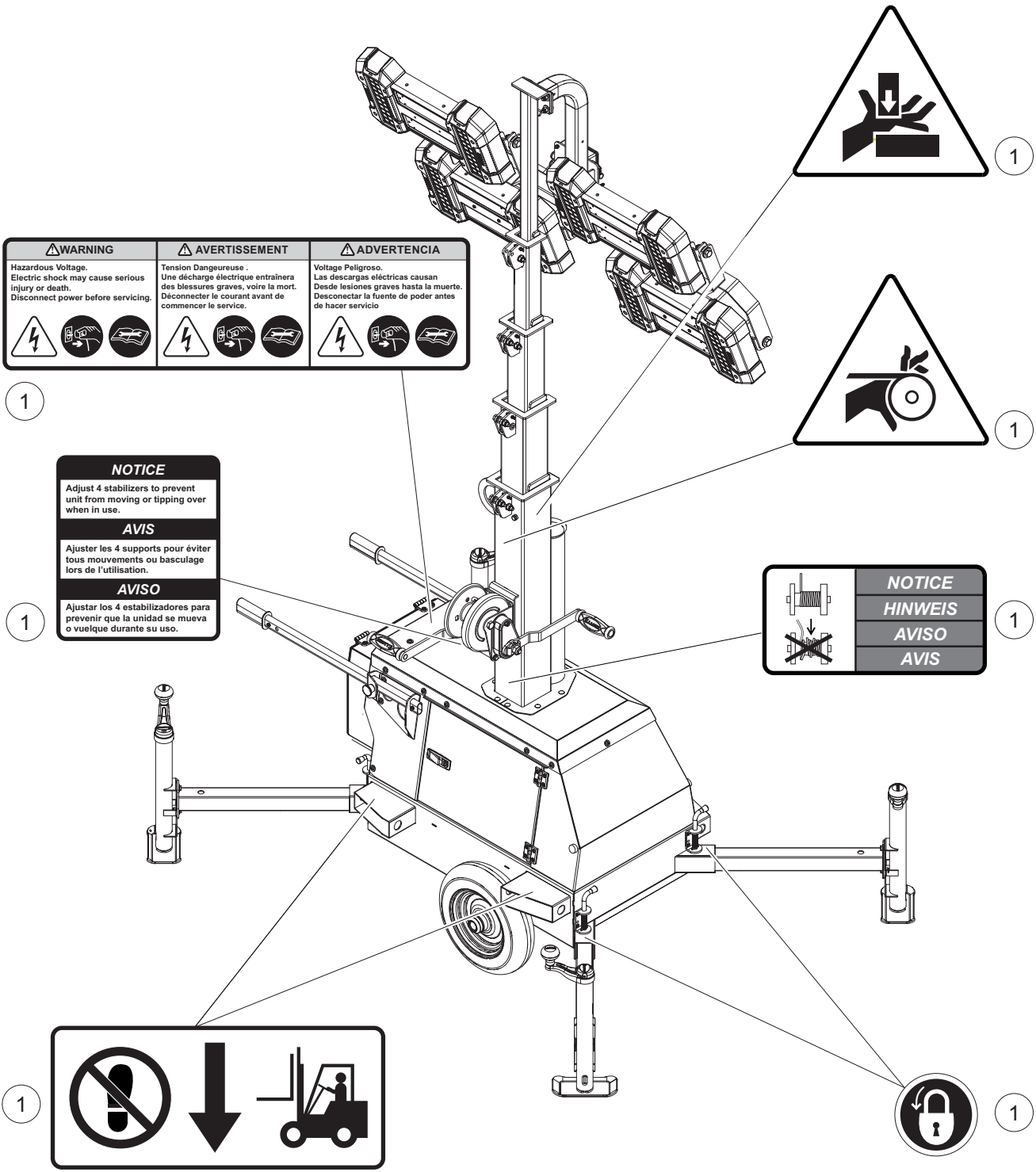

⚠️ WARNING	⚠️ AVERTISSEMENT	⚠️ ADVERTENCIA
Hazardous Voltage. Electric shock may cause serious injury or death. Disconnect power before servicing.	Tension Dangereuse. Une décharge électrique entraînera des blessures graves, voire la mort. Déconnecter le courant avant de commencer le service.	Voltage Peligroso. Las descargas eléctricas causan desde lesiones graves hasta la muerte. Desconectar la fuente de poder antes de hacer servicio.

**NOTICE**  
Adjust 4 stabilizers to prevent unit from moving or tipping over when in use.

**AVIS**  
Ajuster les 4 supports pour éviter tous mouvements ou basculement lors de l'utilisation.

**AVISO**  
Ajustar los 4 estabilizadores para prevenir que la unidad se mueva o vuelque durante su uso.

	<b>NOTICE</b>
	<b>HINWEIS</b>
	<b>AVISO</b>
	<b>AVIS</b>

02230



## UNIT DECALS

---

Item	Part No.	Qty	Description	Notes
1	54939	1	Decals, safety, Rev A	

# UNIT DECALS

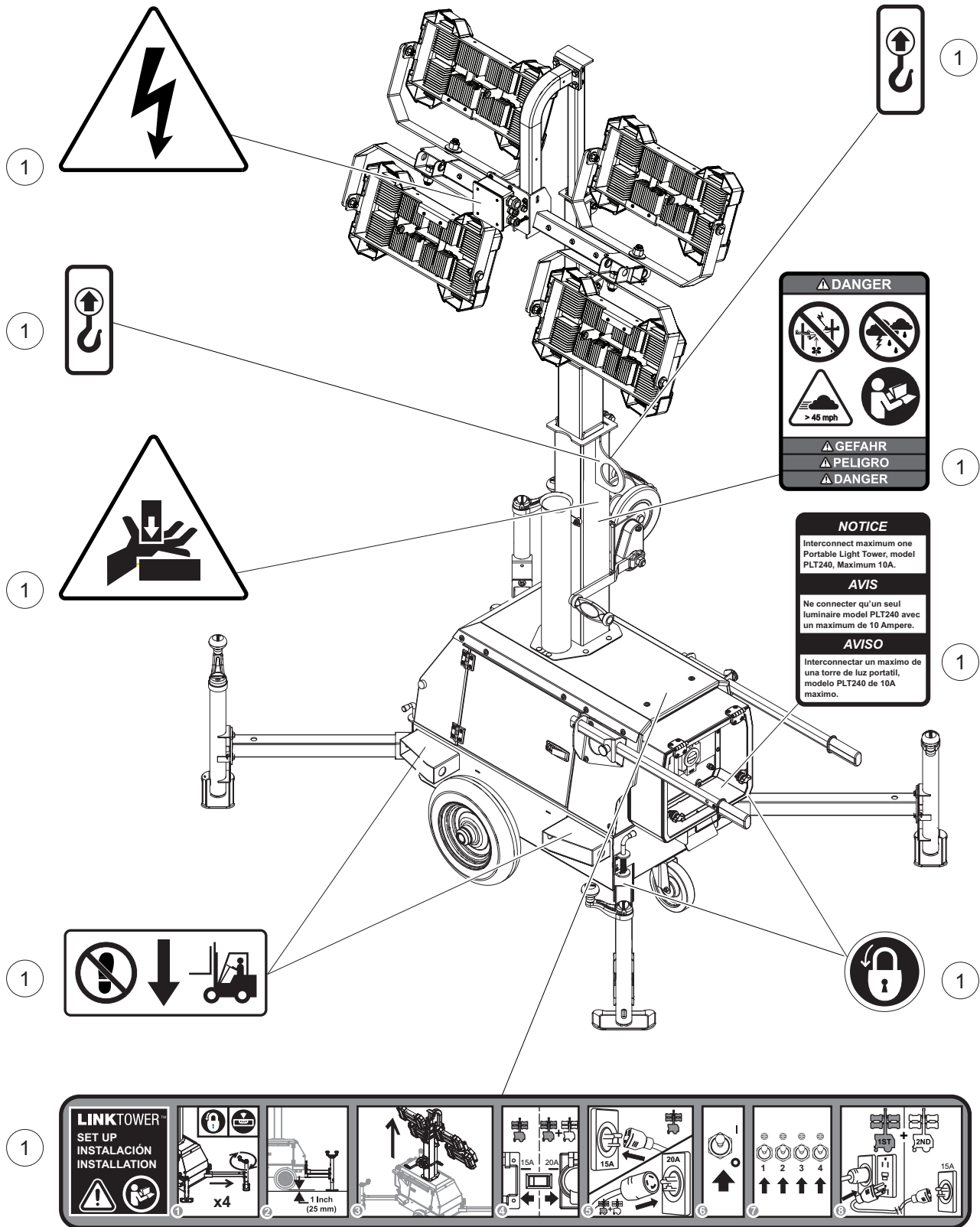

02231

## UNIT DECALS

---

Item	Part No.	Qty	Description	Notes
1	54939	1	Decals, safety, Rev A	

# LIGHTS, DOORS AND CONTROL BOX TO UNIT

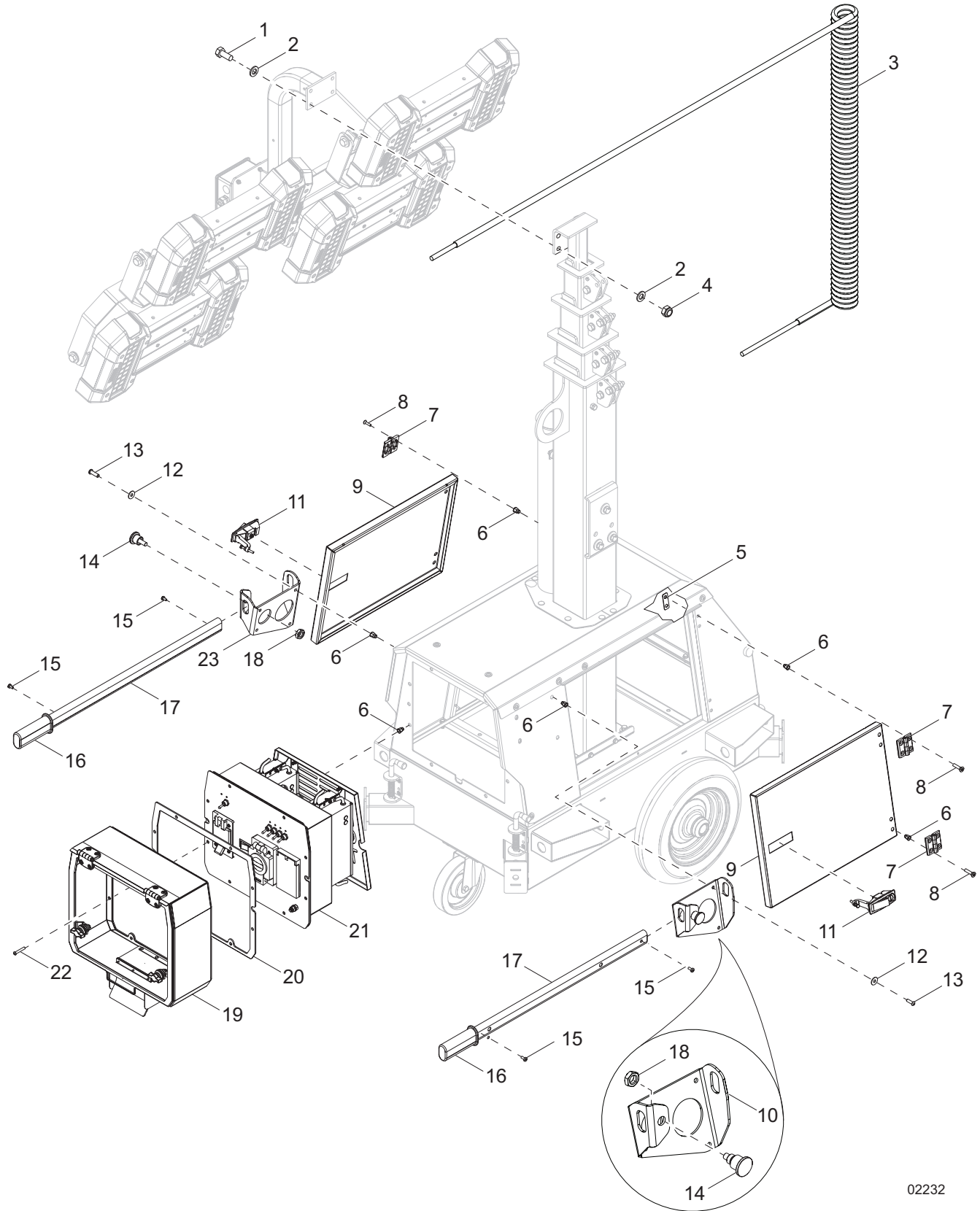

02232

## LIGHTS, DOORS AND CONTROL BOX TO UNIT

Item	Part No.	Qty	Description	Notes
1	60352	4	Screw, .375-16 x 1.25 standard hex, G5	
2	60386	8	Washer, .375 .993/.064	
3	10000026846	1	Cord, coil #14/9 53 in - tail	
4	60358	4	Nut, .375-16 nylock - G5	
5	55089	4	Bracket, hinge mount	
6	69991	34	Insert, M6-1.00 hex .50-3.00mm grip	
7	56538	4	Hinge	
8	69979	16	Screw, M6-1.10 x 20 Phillips flat - SS	
9	56549	2	Panel, enclosure door	
10	56540	1	Bracket, handle mount - right	
11	56539	2	Handle, door - locking	
12	69975	8	Washer, M6 flat	
13	69978	8	Screw, M6-1.00 x 20 button hex	
14	56544	2	Plunger, pin 10MM	
15	69976	4	Screw, M5-.800 x 12 pan Phillips	
16	56543	2	Grip, handle 30MM	
17	56542	2	Handle, grip 30MM x 740MM	
18	69990	2	Nut, M16-1.5 jam, G4	
19	76941	1	Assembly, control panel cover	
20	76929	2	Gasket, control panel	
21	55090	1	Assembly, control box w/drivers	<a href="#">page 20</a>
22	69984	10	Screw, M6-1.00 x 30 button hex	
23	56541	1	Bracket, handle mount - left	

# ENCLOSURE ASSEMBLY

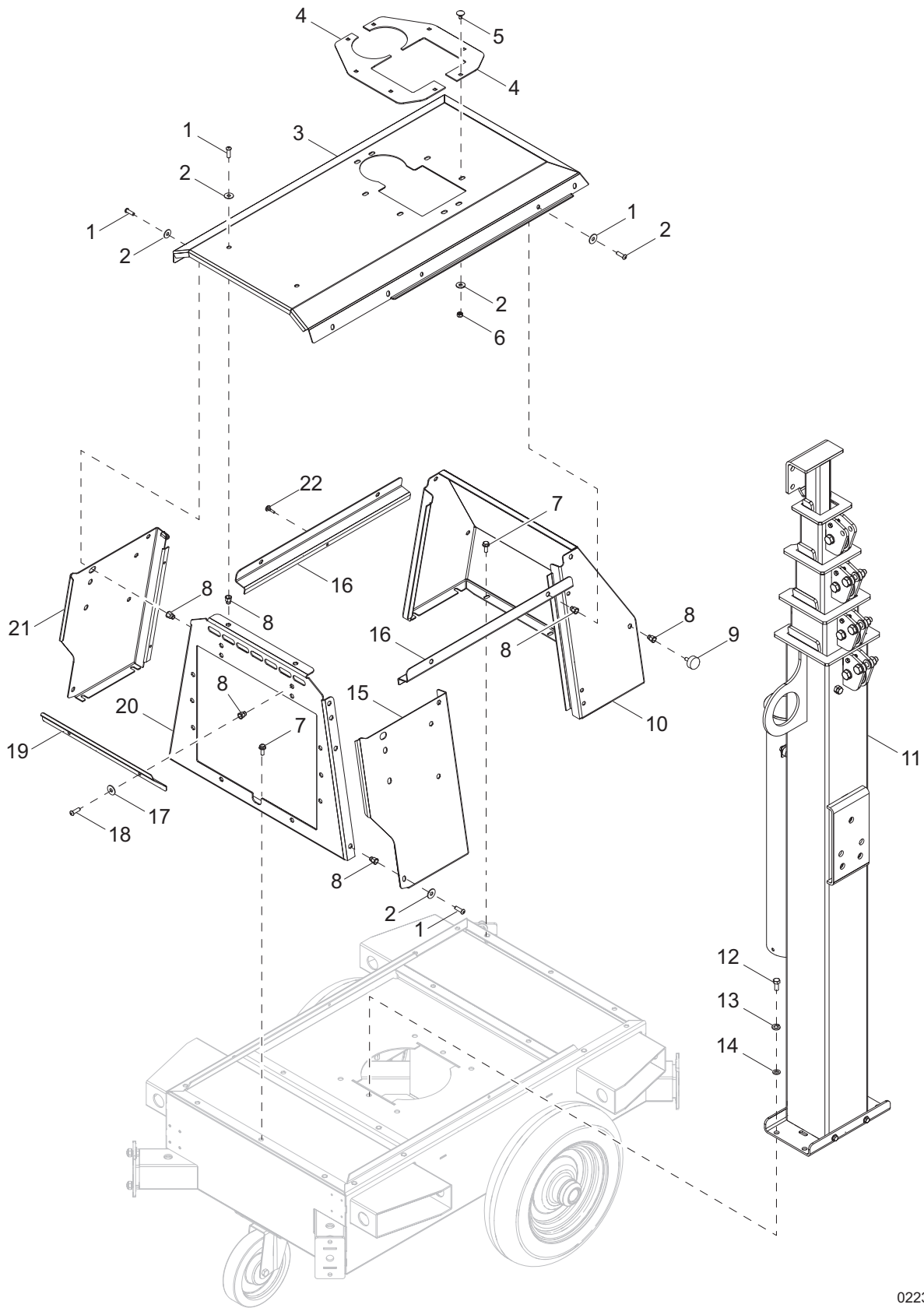

02233

## ENCLOSURE ASSEMBLY

Item	Part No.	Qty	Description	Notes
1	69978	15	Screw, M6-1 x 20 button hex	
2	69975	15	Washer, flat M6	
3	56526	1	Panel, enclosure roof	
4	56535	2	Bracket, mast guide - right	
5	69980	8	Screw, M6-1.00 x 16 carriage, G4	
6	60047	8	Nut, M6 nylock, G8.8	
7	60087	14	Screw, M6-1.00 x 16 serrated flange, G8.8	
8	69991	27	Insert, M6-1.00 hex .50-3.00mm grip	
9	56537	2	Stopper, door - rubber	
10	56525	1	Panel, enclosure - back	
11	56552	1	Assembly, mast	
12	61082	4	Screw, M8-1.25 x 20 standard hex, G8.8	
13	60029	4	Washer, M8 split lock	
14	69981	4	Washer, M8 flat	
15	56524	1	Panel, enclosure - front right	
16	56527	2	Jamb, door - top	
17	69983	2	Washer, M6 flat	
18	69982	2	Screw, M6-1.0 x 16 button hex	
19	56522	1	Cover, enclosure - vent	
20	56521	1	Panel, enclosure - front	
21	56523	1	Panel, enclosure -front left	
22	56536	4	Stopper, door jamb - rubber	

# LIGHT MAST ASSEMBLY

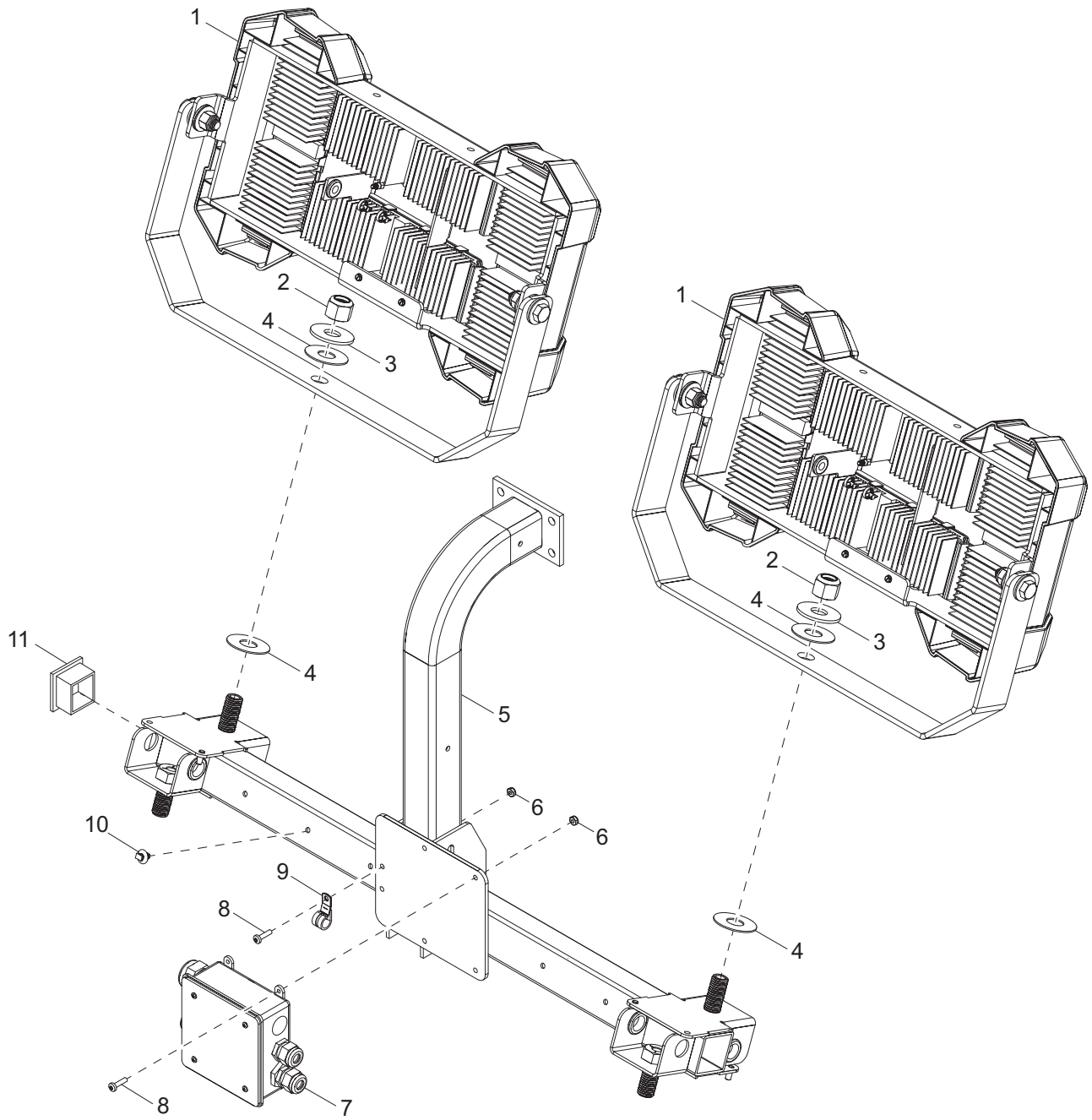

02234



## LIGHT MAST ASSEMBLY

---

<b>Item</b>	<b>Part No.</b>	<b>Qty</b>	<b>Description</b>	<b>Notes</b>
1	73188	4	Assembly, LED light - 4 module, horizontal	
2	60584	4	Nut, .750-10 nylock	
3	60247	4	Washer, .750 flat 2.020/.130	
4	63357	8	Washer, .750 flat 2.0/.062 - plastic	
5	73200B	1	Weldment, mast, crossbar	
6	60061	5	Nut, 10-32 nylock	
7	72174SRV	1	Assembly, mast box - LED	
8	60062	5	Screw, 10-32 x .750 pan Phillips, G2	
9	16143	1	Clamp, tubing .500	
10	66685	6	Mount, cable tie	
11	31254	2	Plug, 2.0 square x .125 wall tube, plastic	

# LIGHT ASSEMBLY

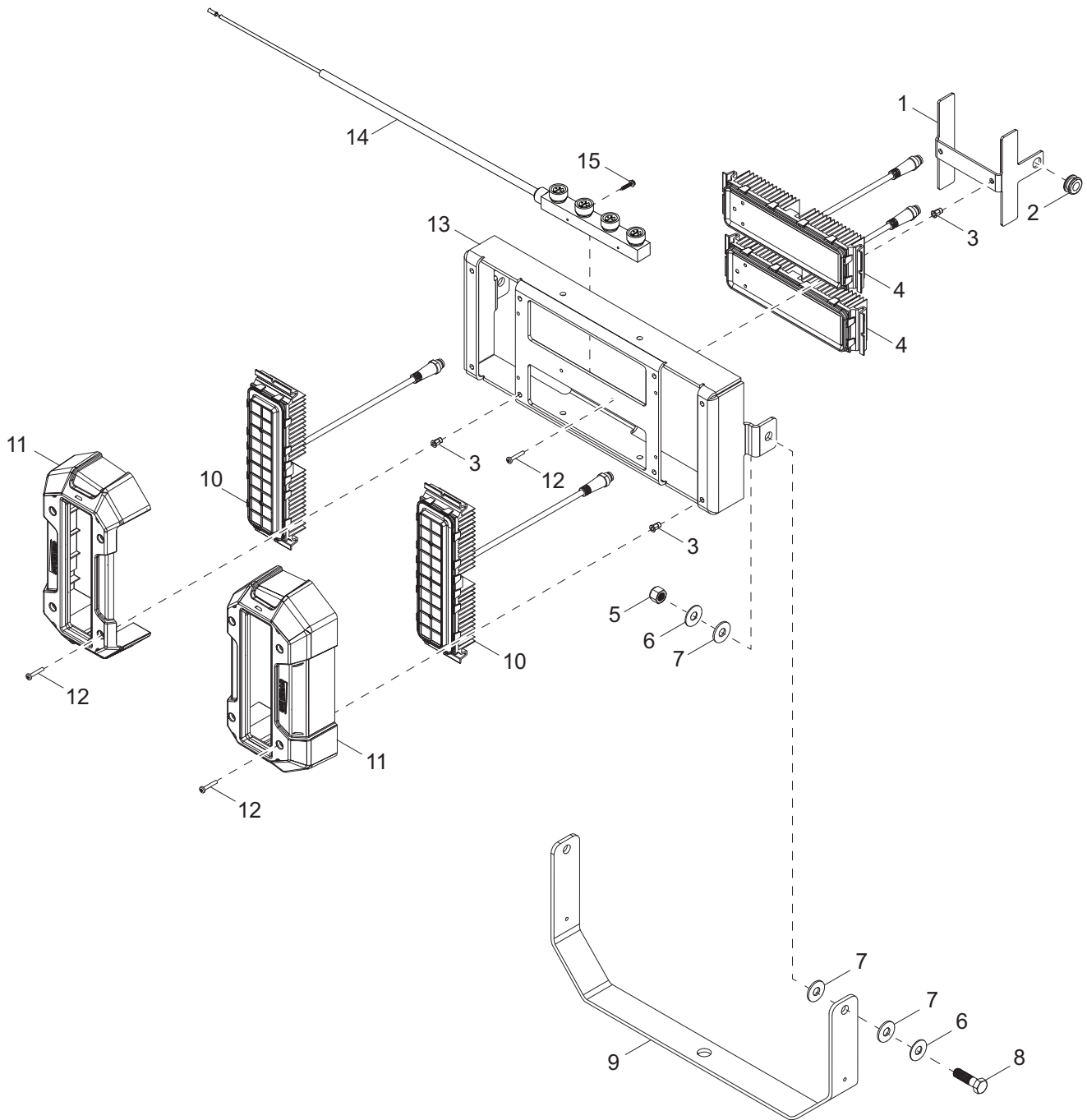

02235

## LIGHT ASSEMBLY

Item	Part No.	Qty	Description	Notes
1	72107B	1	Bracket, mounting - LED module	
2	73227	1	Grommet, .375ID x .125 x .875OD - rubber	
3	73206	10	Insert, 10-32 hex - .130-.225 grip, threaded	
4	72118	2	Module, LED 90°	
5	62221	2	Nut, .500-13 nylock, G5	
6	60700	4	Washer, .500 flat 1.25/.060 - SS	
7	72134	6	Washer, .500 nylon 1.25/.100	
8	60830	2	Screw, .500-13 x 1.75 hex - SS	
9	73199B	1	Trunnion, LED light - horizontal	
10	72119	2	Module, LED 60°	
11	73181	2	End cap, LED light	
12	73220	10	Screw, 10-32 x 1.0 hex w/nylon washer	
13	73189B	1	Frame, support - 4 LED module, horizontal	
14	72120	1	Connector block, 4 module	
15	73219	2	Screw, 6-20 x .750 sheet metal - SS	
	73188	1	Assembly, LED light - 4 module, horizontal	Items 1-13

# MAST JUNCTION BOX ASSEMBLY

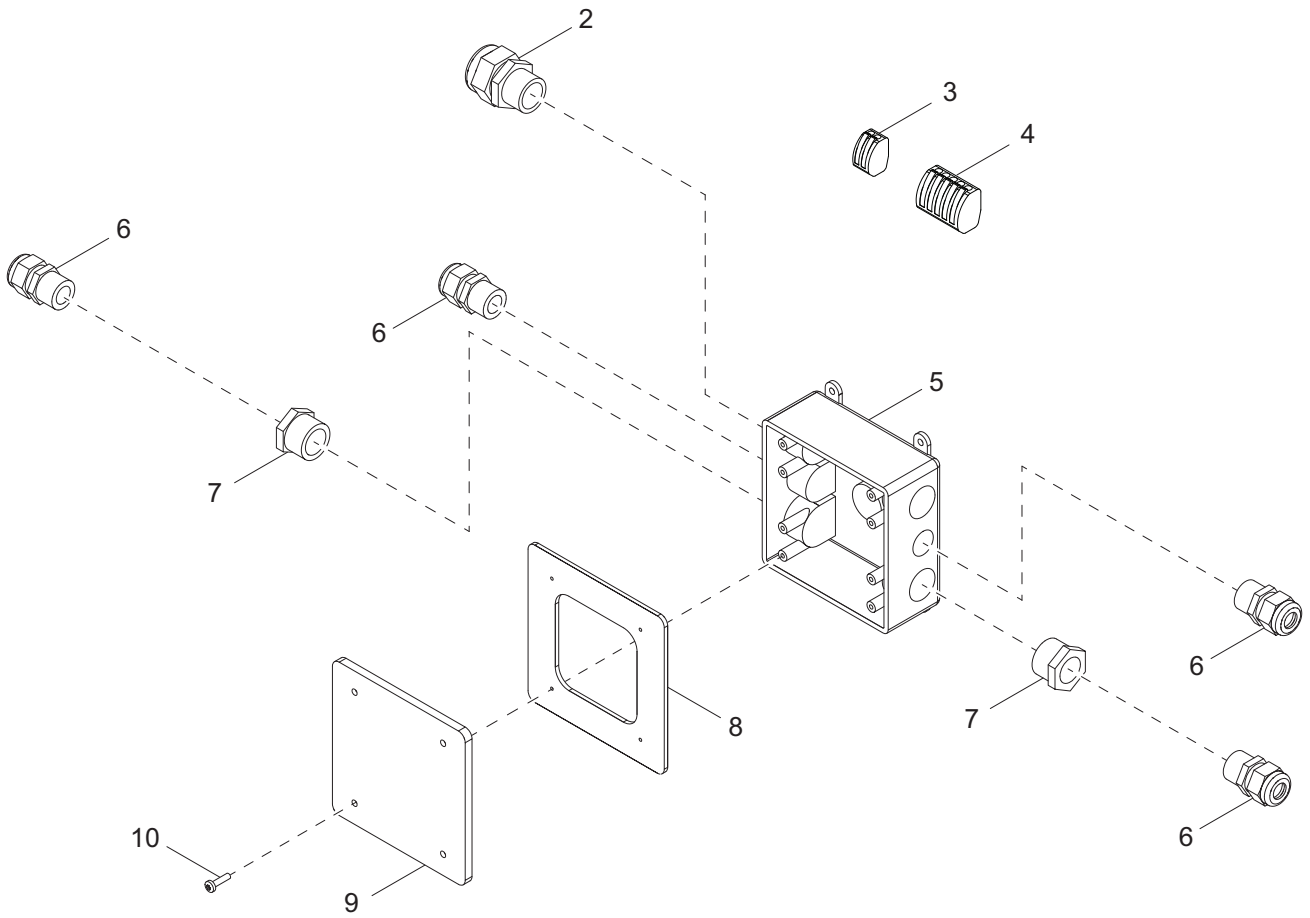
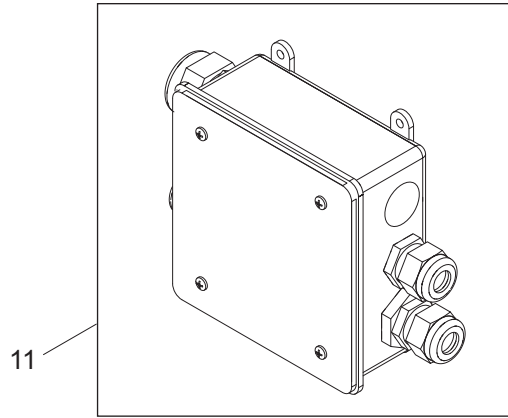
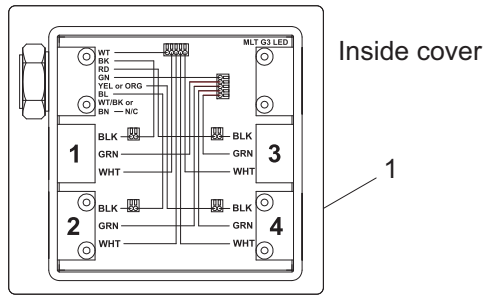

02119

## MAST JUNCTION BOX ASSEMBLY

---

Item	Part No.	Qty	Description	Notes
1	55046	1	Decal, mast junction box	
2	14656	1	Strain relief, .750NPT water tight	
3	66100	8	Connector, 2 position	
4	12094	1	Box, junction	
5	15864	4	Strain relief, .500NPT water tight	
6	60755	2	Fitting, straight .750MNPT x .500FNPT, nylon	
7	13749SRV	1	Gasket, junction box - HFI 281000	
8	12109	1	Cover, box, 2-gang plastic	
9	60424	4	Screw, 6-32 x .750 pan Phillips, G2	

# MAST ASSEMBLY

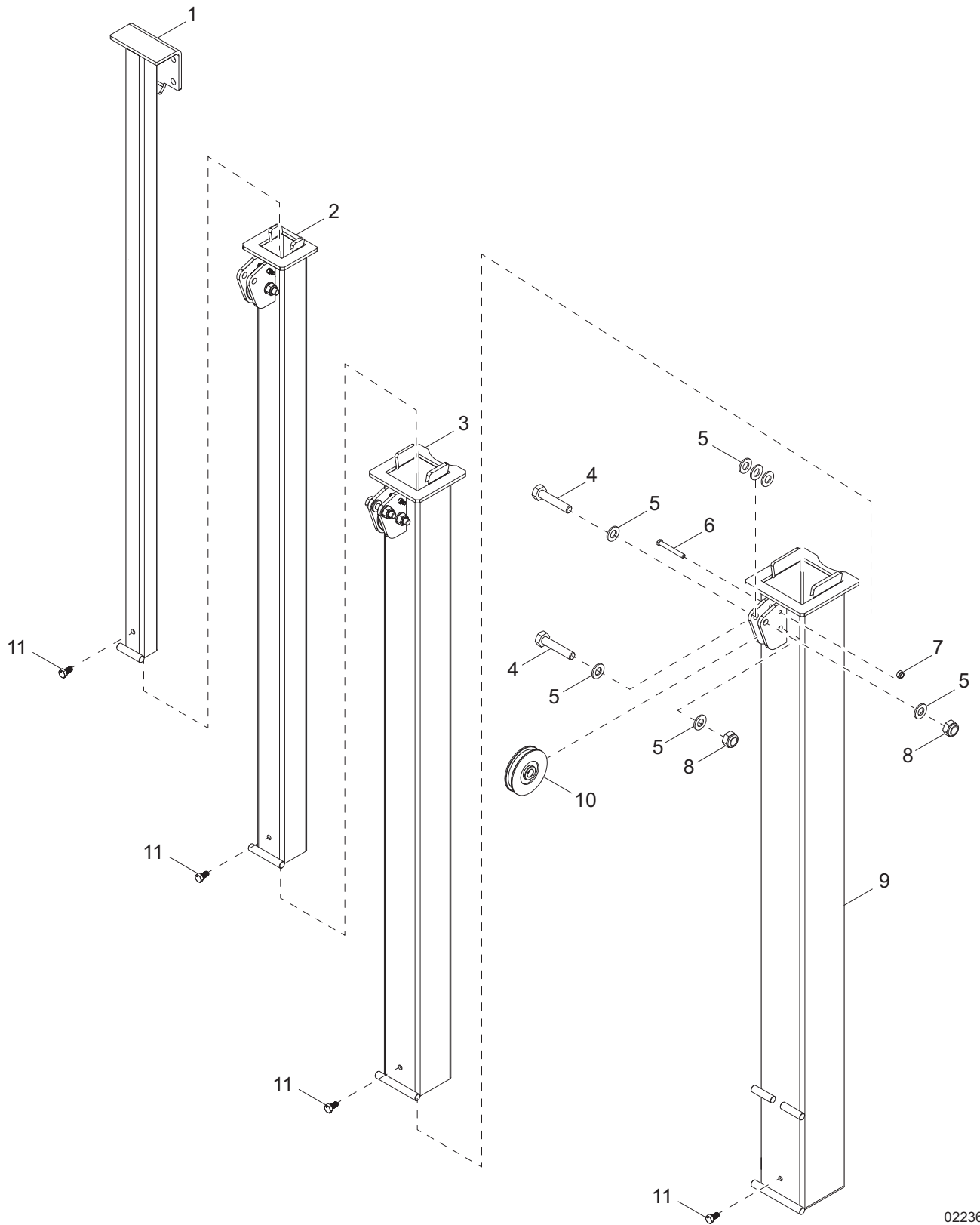

02236

## MAST ASSEMBLY

Item	Part No.	Qty	Description	Notes
1	56532	1	Weldment, mast 40MM	
2	56531	1	Weldment, mast 60MM	
3	56530	1	Weldment, mast 80MM	
4	69970	5	Screw, M10-1.50 x 55 standard hex, G8.8	
5	69971	16	Washer, M10 flat	
6	69969	3	Screw, M5-.80 x 40 standard hex, G8.8	
7	60038	3	Nut, M5-.80 nylock, G6	
8	60097	5	Nut, M10-1.50 nylock, G8.8	
9	56529	1	Weldment, mast 100MM	
10	56534	3	Pulley, 62mm x 10.5mm	
11	60113	4	Screw, M8-1.125 x 16 standard hex, G8.8	
--	56545	1	Cable, .5 x 88.6 long	top cable
--	56546	1	Cable, .5 x 44.9 in. long	bottom cable
--	56547	2	Cable, .5 x 45.7 in. long	middle cable

# MAST BASE ASSEMBLY

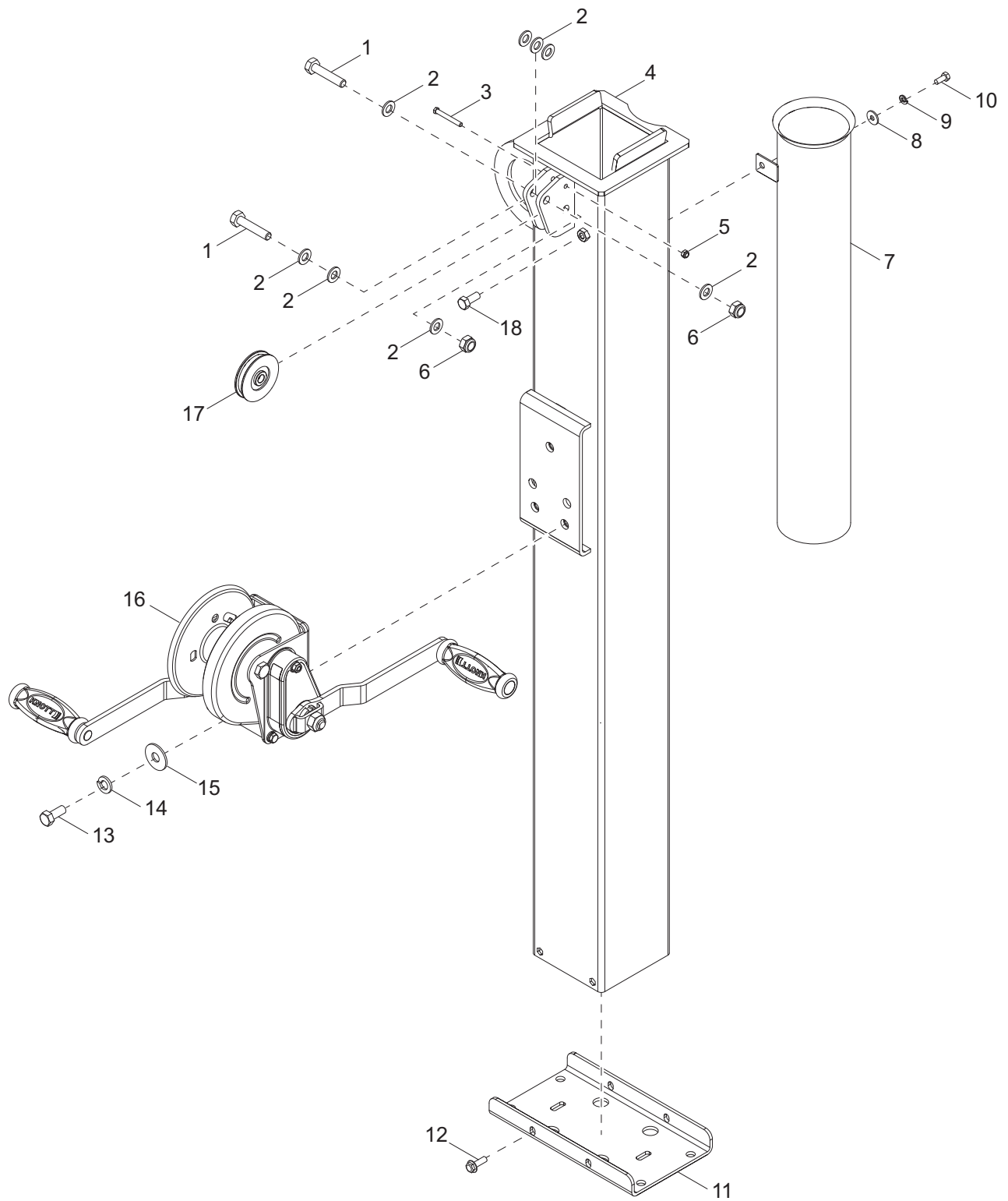

02237



## MAST BASE ASSEMBLY

Item	Part No.	Qty	Description	Notes
1	69970	2	Screw, M10-1.50 x 55 standard hex, G8.8	
2	69971	7	Washer, M10 flat	
3	69969	1	Screw, M5-.80 x 40 standard hex, G8.8	
4	56528	1	Weldment, mast 120mm	
5	60038	1	Nut, M5-.80 nylock, G6	
6	60097	2	Nut, M10-1.50 nylock, G8.8	
7	56533	1	Tube guide, coil cord	
8	69975	1	Washer, M6 flat	
9	38522	1	Washer, M6 split lock	
10	69974	1	Screw, M6-1.0 x 12 standard hex, G8.8	
11	56520	1	Bracket, mast mount	
12	60087	4	Screw, M6-1.00 x 16 serrated flange hex, G8.8	
13	69972	3	Screw, M10-1.50 x 25 standard hex, G8.8	
14	60026	3	Washer, M10 split lock	
15	69973	3	Washer, M10 flat	
16	72127	1	Winch, manual 1500lb - dual handle	
17	56534	1	Pulley, 62mm x 10.5mm	
18	61082	2	Screw, M8-1.25 x 20 standard hex, G8.8	

# CONTROL PANEL COVER

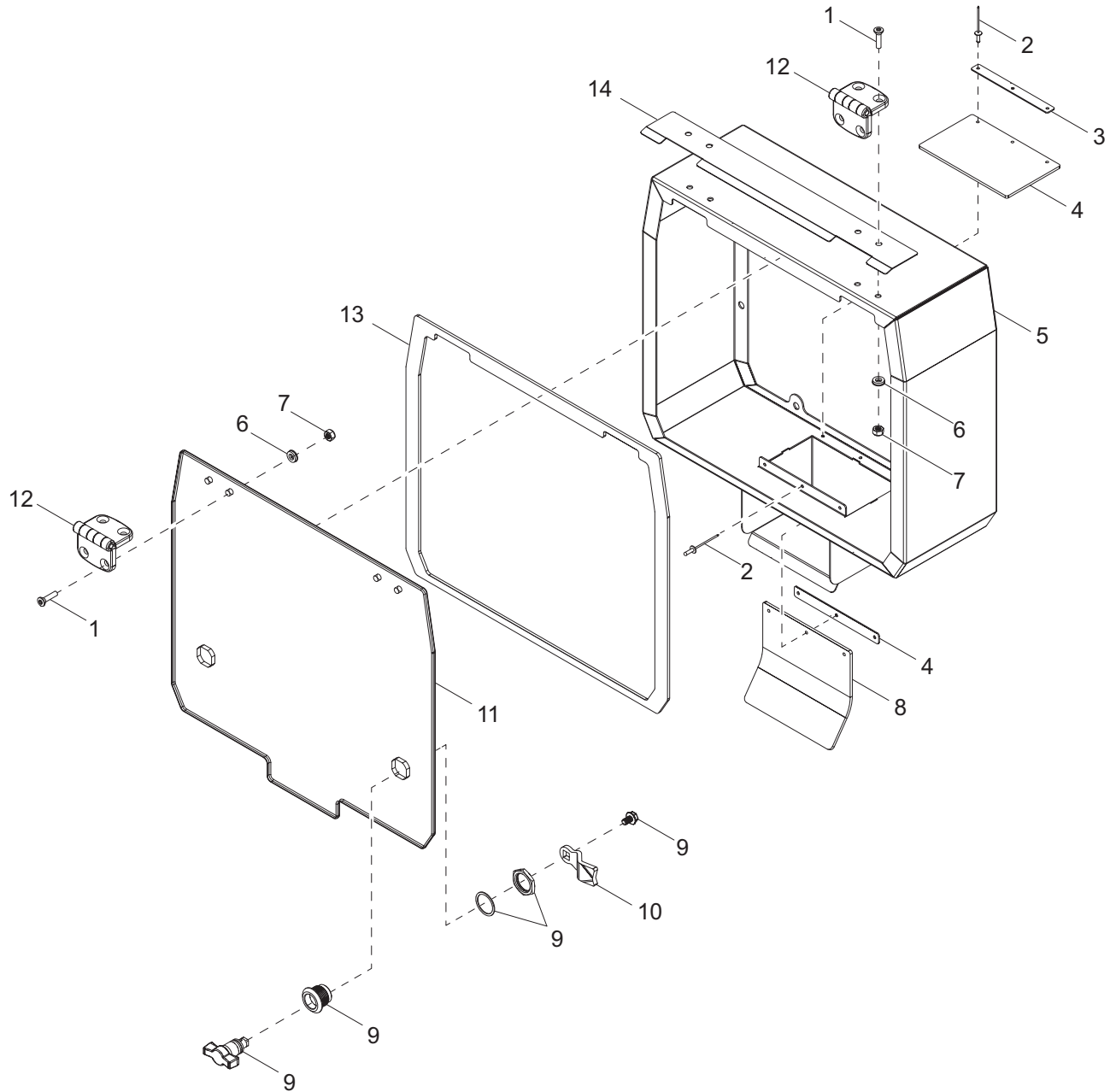

02238

## CONTROL PANEL COVER

Item	Part No.	Qty	Description	Notes
1	69967	8	Screw, M6 x 1.00 - 20 flat Phillips - SS	
2	60267	6	Rivet, .125 dia x .191 to .270 grip	
3	76949B	2	Plate, backing	
4	10000007754	1	Flap, cover - rubber	
5	76940	1	Weldment, control panel cover	
6	69968	8	Washer, sealing .26 x .50 - SS/neoprene	
7	60047	8	Nut, M6-1.00 nylock, G8.8	
8	76943	1	Flap, rubber	
9	76945	2	Latch, wing knob	
10	76946	2	Cam, latch 8mm offset	
11	76925	1	Lid, control panel cover	
12	76944	2	Hinge, butt - 6mm mount	
13	76930	1	Gasket, control panel lid	
14	10000007540	1	Drip edge	

# CONTROL PANEL ASSEMBLY (1 OF 3)

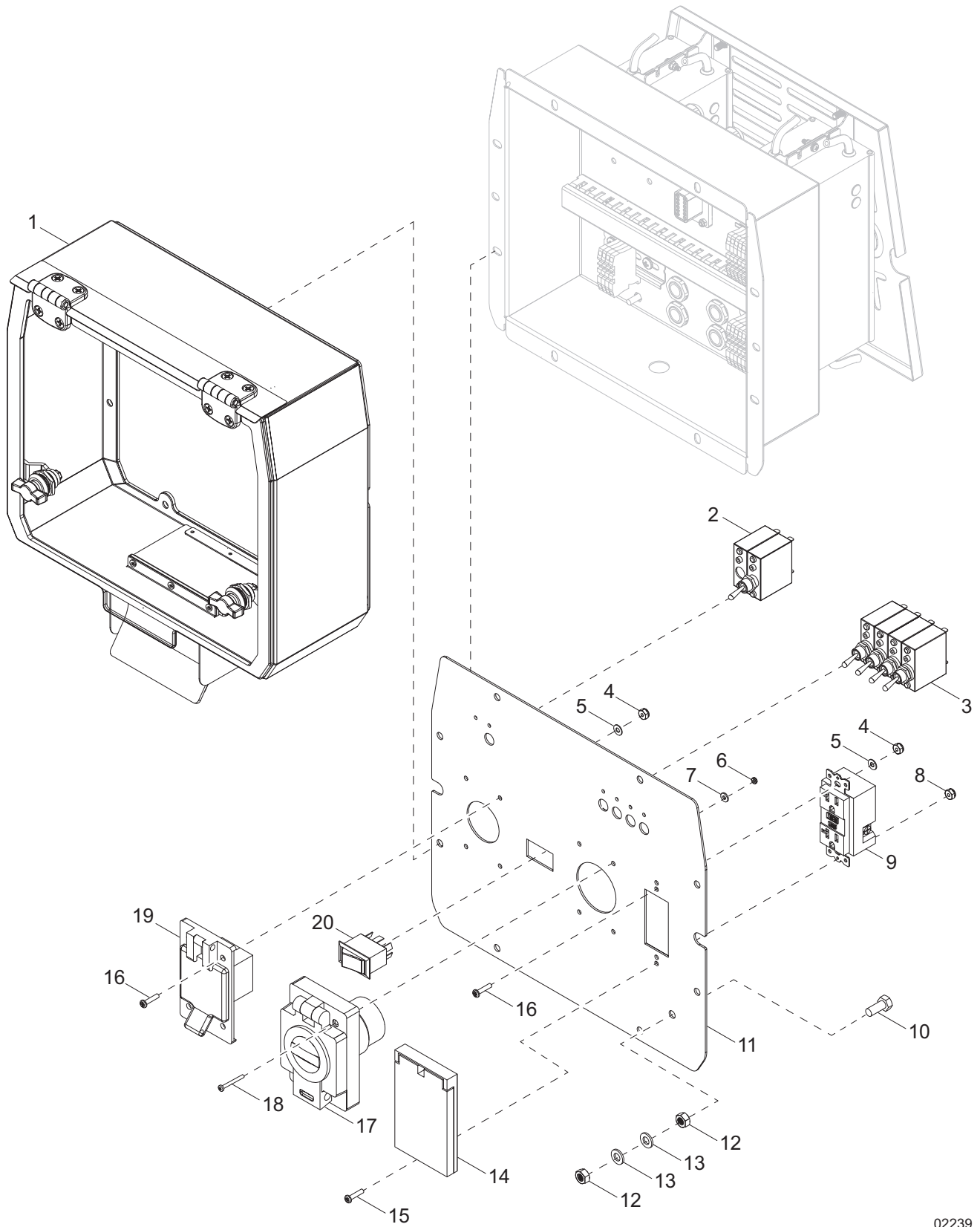

02239

## CONTROL PANEL ASSEMBLY (1 OF 3)

Item	Part No.	Qty	Description	Notes
1	76941	1	Assembly, control panel cover	
2	75015	1	Breaker, 2-pole, 15A & 20A - dual linked	
3	75016	4	Switch, lights, 5A	
4	60270	6	Nut, 8-32 nylock	
5	60269	6	Washer, #8 flat .433/.036	
6	60728	4	Nut, 6-32 nylock, G5	
7	60289	4	Washer, #6 flat	
8	60758	2	Nut, 4-40 nylock, G2	
9	14130	1	Receptacle, 120V/20A GFI	
10	69985	1	Screw, M8-1.25 x 25 standard hex - brass	
11	56510	1	Plate, control panel	
12	69986	2	Nut, M8-1.25 - brass	
13	69987	2	Washer, M8 flat - brass	
14	37017	1	Cover, receptacle - weather proof	
15	60757	2	Screw, 4-40 x .750 pan Phillips, G2	
16	60694	6	Screw, 8-32 x .750 pan Phillips - SS	
17	75014	1	Receptacle, 120V/20A inlet w/cover	
18	69988	4	Screw, 6-32 x 1.25 pan Phillips - SS	
19	65385	1	Receptacle, 120V/15A inlet w/cover	
20	68530	1	Switch, rocker DPDT - on/on	
	55090	1	Assembly, control box with drivers	

# CONTROL PANEL ASSEMBLY (2 OF 3)

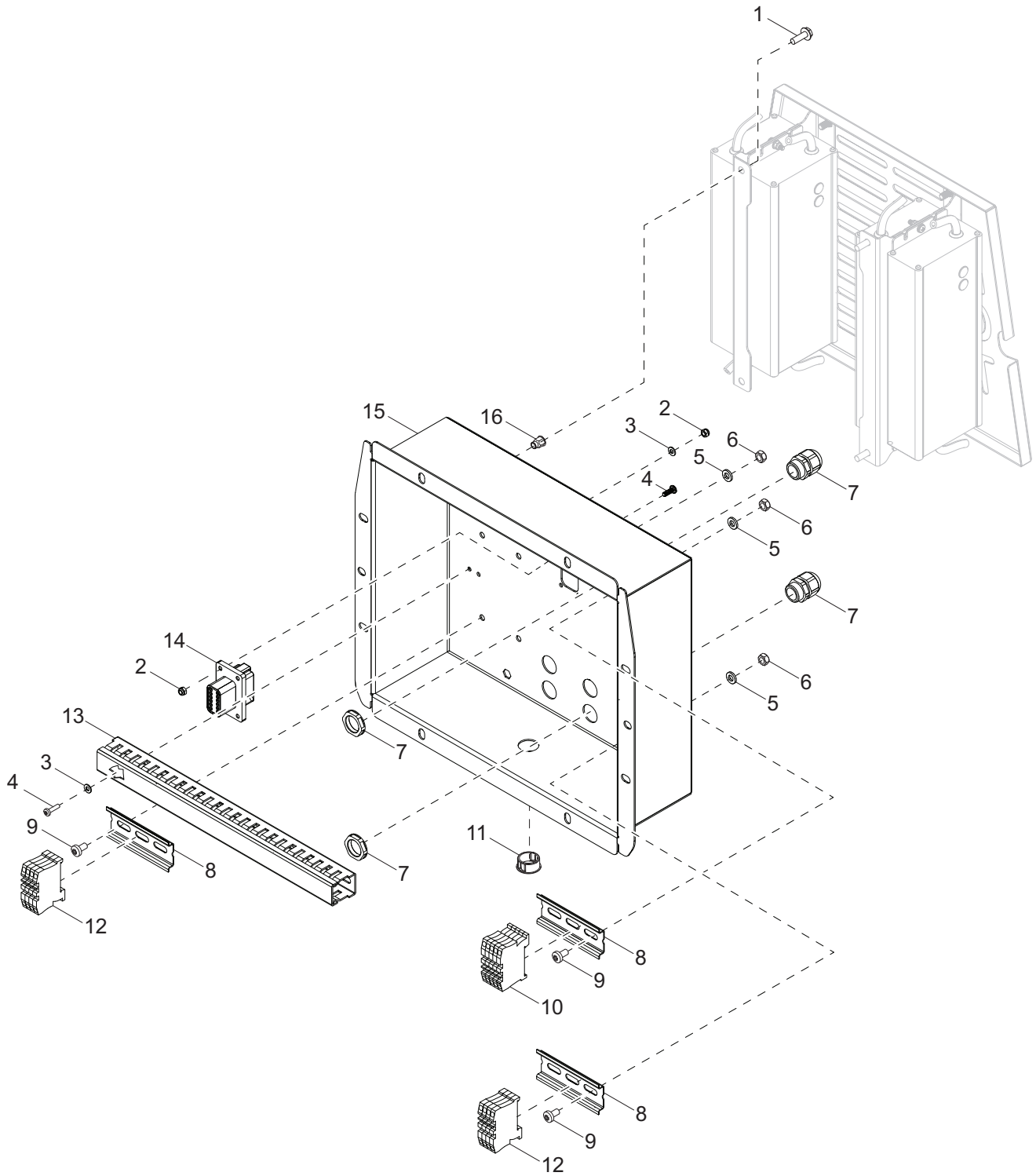

02240

## CONTROL PANEL ASSEMBLY (2 OF 3)

Item	Part No.	Qty	Description	Notes
1	60087	4	Screw, M6-1.00 x 16 serrated flange hex, G8.8	
2	60051	2	Nut, M4-.700 nylock, G8.8	
3	60084	4	Washer, M4 flat	
4	60091	6	Screw, M4-.700 x 12 pan Phillips, G4.8	
5	69983	6	Washer, M6 flat	
6	60047	6	Nut, M6-1.00 nylock, G8.8	
7	56503	8	Connector, cable compression - nylon	
8	56506	3	Rail, terminal mount	
9	63288	6	Screw, M6-1.00 x 12 pan Phillips, G8.8	
10	56508	5	Terminal block, 2 conductor 12AWG - green	
11	56609	1	Plug, knockout 20mm	
12	56507	8	Terminal block, 2 conductor 12AWg - gray	
13	56505	1	Duct, wire routing	
14	66695	1	Connector, Deutsch 12 pos recept/pin - flange	
15	56504	1	Housing, electrical component	
16	69991	4	Insert, M6-1.00 hex .50-3.00mm grip	

# CONTROL PANEL ASSEMBLY (3 OF 3)

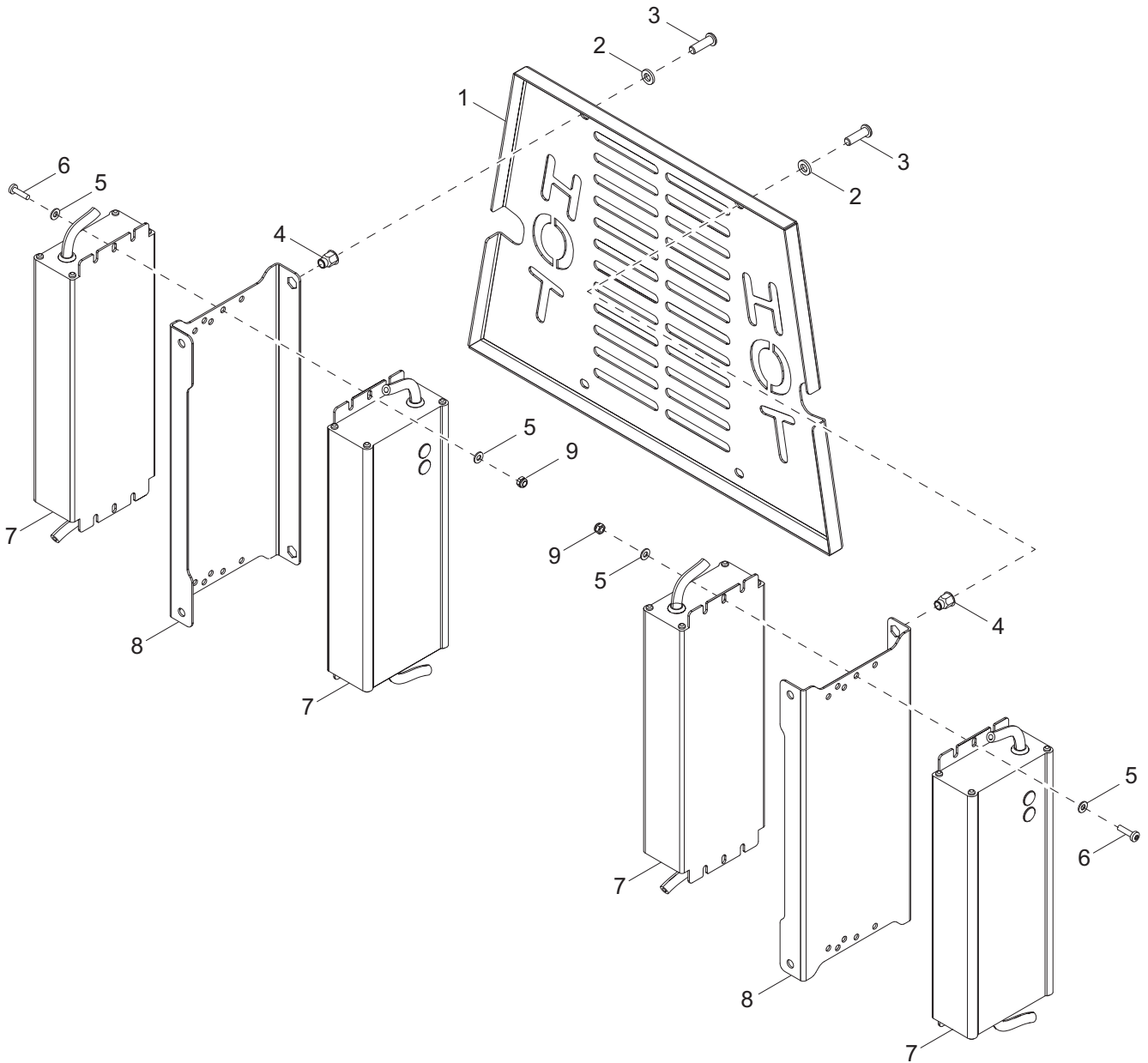

02241



## CONTROL PANEL ASSEMBLY (3 OF 3)

---

Item	Part No.	Qty	Description	Notes
1	72180	1	Cover, LED driver	
2	69983	4	Washer, M6 flat	
3	69982	4	Screw, M6-1.00 x 16 button hex	
4	69991	4	Insert, M6-1.00 hex .50-3.00mm grip	
5	60084	8	Washer, M4 flat	
6	53280	4	Screw, M4-700 x 16 pan Phillips	
7	72178	4	Driver, LED 30V, 10.7A-CC 320W	
8	72179	2	Bracket, driver mount	
9	60051	4	Nut, M4-.700 nylock, G8.8	

# TRAILER ASSEMBLY

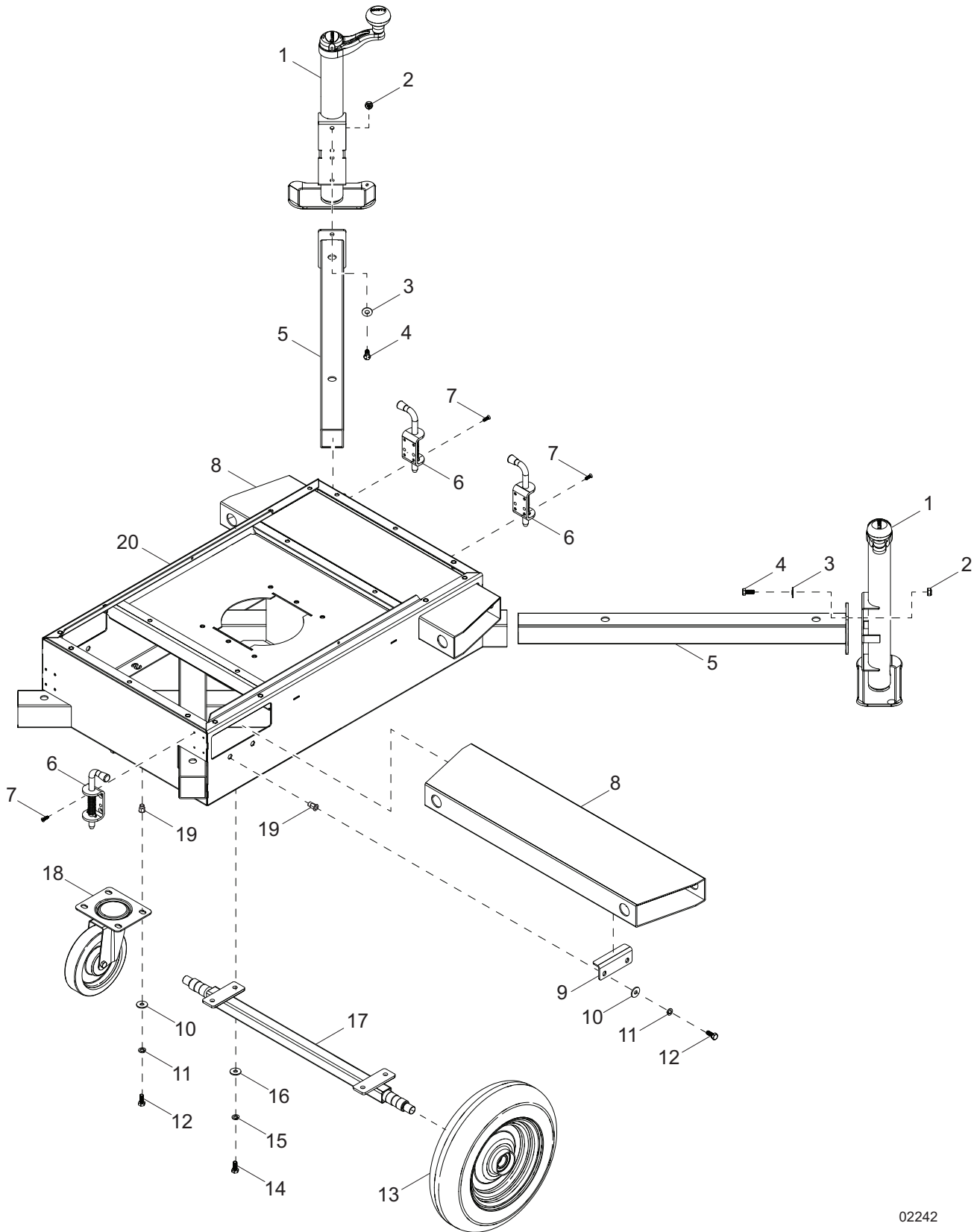

02242

## TRAILER ASSEMBLY

Item	Part No.	Qty	Description	Notes
1	54788	4	Jack, top wind, 1200lb - large foot	
2	62079	8	Nut, .312 nylock - jam	
3	60119	8	Screw, M12-1.75 x 20 serrated flange hex, G8.8	
4	60168	8	Screw, .312-18 x .750 standard hex, G5	
5	56519	4	Weldment, outrigger/jack mount	
6	56516	4	Spring pin, M5 mount	
7	69977	16	Screw, M5-.80 x 16 flat Phillips	
8	56517	2	Tube guide, forklift	
9	56518	4	Bracket, tube guide - forklift	
10	69981	12	Washer, M8 flat	
11	60029	12	Washer, M8 split lock	
12	61082	12	Screw, M8-1.25 x 20 standard hex	
13	56514	2	Wheel, 3.50 x 8.00 rubber - full	
14	53334	4	Screw, M6-1.00 x 20 hex, G8.8	
15	38522	4	Washer, M6-.250 split lock	
16	69975	4	Washer, M6 flat	
17	56513	1	Weldment, axle and hub	
18	56515	1	Caster w/lock, 6.00	
19	69992	12	Insert, M8-1.25 hex, .50 -3.50mm grip	
20	56512	1	Weldment, frame base	

# RECOMMENDED SPARE PARTS

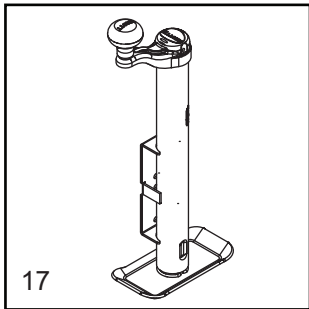
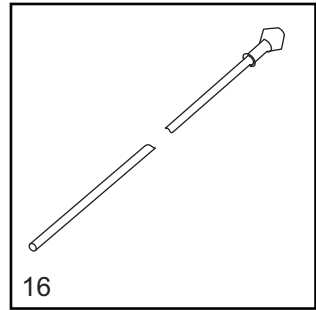
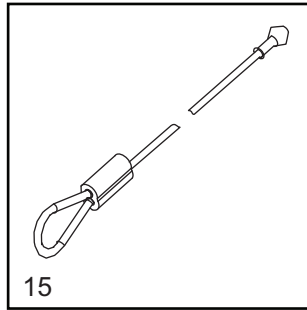
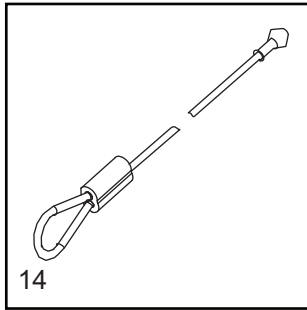
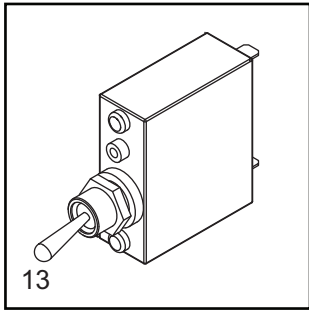
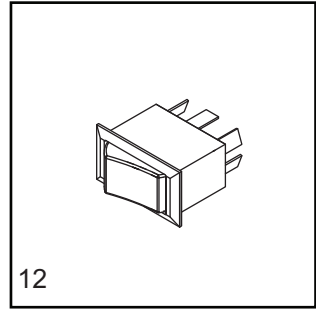
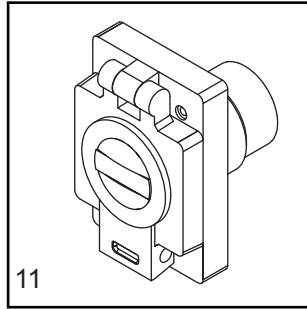
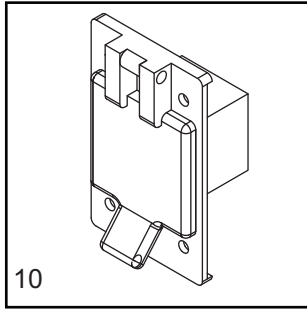
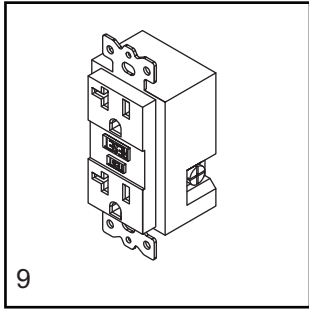
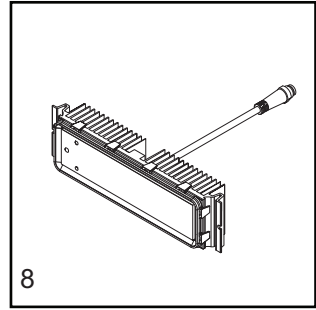
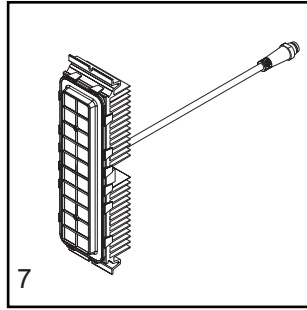
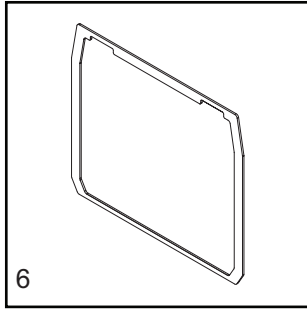
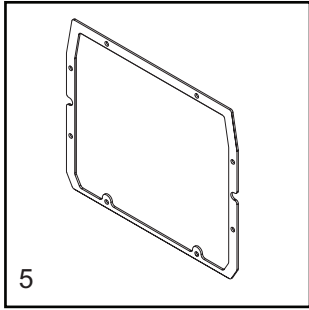
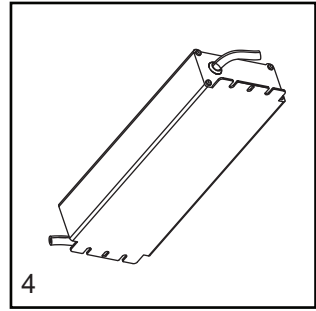
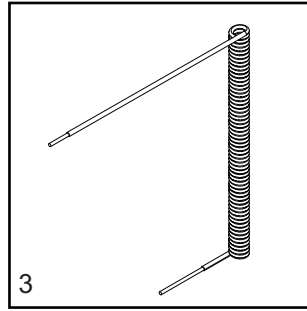
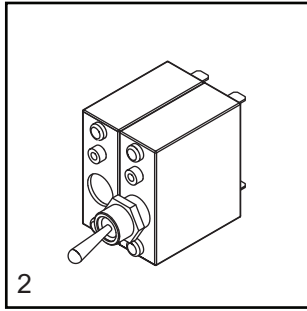
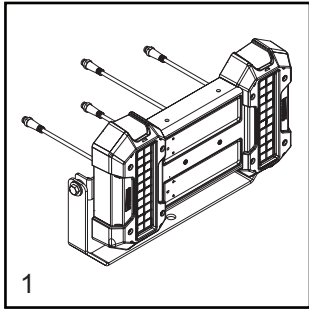

**ELECTRICAL**

1. Assembly, LED light - 4 module horizontal .....	73188
2. Breaker, 2-pole, 15A and 20A dual.....	75015
3. Coil cord .....	10000026846
4. Driver, LED 30V, 10.7A-CC 320W.....	72178
5. Gasket, control panel .....	76929
6. Gasket, control panel lid.....	76930
7. Module, LED 60° .....	72119
8. Module, LED 90° .....	72118
9. Receptacle, 120V/20A GFI.....	14130
10. Receptacle, 120V/15A inlet w/cover.....	65385
11. Receptacle, 120V/20A inlet w/cover .....	75014
12. Switch, rocker DPDT - on/on.....	68530
13. Switch, lights 5A .....	75016

**MAST**

14. Cable, .5 x 88.6 long (top cable) .....	56545
15. Cable, .5 x 44.9 long (bottom cable) .....	54546
16. Cable, .5 x 45.7 long (middle cable).....	54547

**TRAILER**

17. Jack, top wind .....	54788
--------------------------	-------





Part No. 54801 Rev. B 03/13/2018

©2018 Generac Mobile Products, LLC  
All rights reserved.

Specifications are subject to change without notice.  
No reproduction allowed in any form without prior written consent  
from Generac Mobile Products, LLC.

**GENERAC**

**MOBILE  
PRODUCTS**

Generac Mobile Products, LLC  
215 Power Drive, Berlin, WI 54923

[GeneracMobileProducts.com](http://GeneracMobileProducts.com) | 800-926-9768 | 920-361-4442